

500 – Gallon Pump Tank

5,060 lbs

6,060 lbs w/ 8" cover

Enlarged Detail

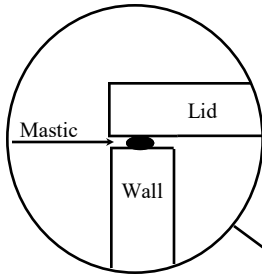

TOP VIEW

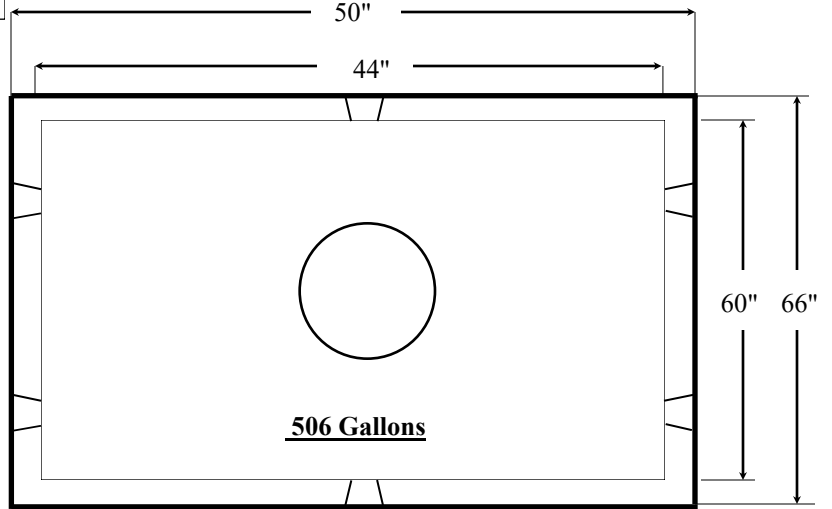

SIDE VIEW

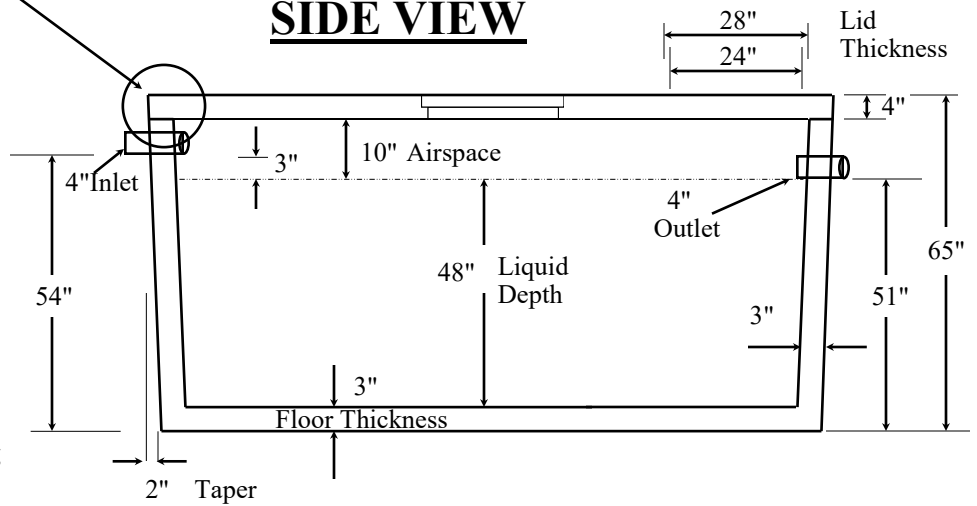

Manhole Lids/Opening

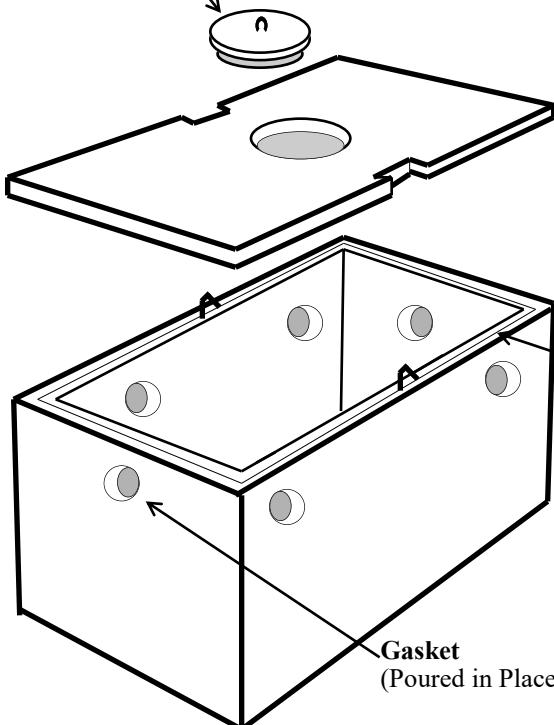

4" Cover Weight: 1,000 lbs
8" Cover Weight: 2,000 lbs

4,000 psi concrete minimum after 28 days.
Design conforms with 310 CMR 15.00 DEP
Title 5 Regulations for septic tanks.
Reinforcement per ASTM C1227

500 – Gallon Pump Tank



978-939-5712 Ext 3